

CEPS-M-110G

Plenum Rated Emergency Inverter Series



The CEPS-M-100G Series of mini inverters is an easy solution for emergency power needs. Designed with LVS advanced Pure Sine Wave technology, the mini inverters provide direct AC power and full illumination to all lighting sources including LED, fluorescent, HID quartz and screw-based LED lamps. With an ultra-wide .5 lead to .5 lag load power factor range, LVS inverters offer unmatched compatibility, allowing existing fixtures to be used for both normal operation and emergency lighting without affecting the aesthetic design of the space.

Catalog #		Type
Project		
Comments		Date
Prepared by		

ELECTRICAL SPECIFICATIONS

INPUT

Input Voltage.....120 or 277V, 1-phase 2-wire +10% -15%
 Input Frequency.....60Hz. +/- 3%
 Input Rating.....138VA
 Input Current.....1.5 amps at 120V or 0.6 amps at 277V
 Harmonic Distortion.....<10% for resistive load

OUTPUT

Output Voltage.....120 or 277V, 1-phase 2-wire
 Static Voltage.....Load current change +/-2%
 Dynamic Voltage.....+/-10% load step change
 Harmonic Distortion.....< 3% THD for linear load
 Frequency.....60Hz. +/- .05 Hz. during emergency mode
 Load Power Factor......5 leading to .5 lagging
 Inverter Overload.....250% for 16 cycles, 110% continuous
 Output Types.....Normally on, normally off, or switched
 Crest Factor.....2.8

OTHER

Compatible Light Sources.....LED, Fluorescent, HID, Incandescent , Quartz
 Transfer Time.....2-10 milliseconds
 Emergency Operation.....90 minutes or more
 Operating Temp. Inverter.....32° - 104° F
 Operating Temp. Battery.....68° - 86° F (per UL-924)
 Battery.....Valve regulated lead acid (VRLA)
 Warranty.....3/10 Prorated



CEPS-M-110G
 Plenum Rated
 Emergency Inverter Series
110VA

FEATURES

- PWM/MOSFET Pure Sine Wave inverter technology
- UL 924 self-testing and self-diagnostics
- High crest factor capabilities
- Compatible with all light sources including LED, HID, fluorescent, incandescent, quartz and electronic low-voltage lighting
- Ultra-wide power factor range from 0.5 leading to 0.5 lagging
- Remote Mount - No distance limitations depending on wattage and wire selected
- Plenum Rated

- High efficiencies, runs cool, no fans required
- Input fuse and battery fuse protection
- Three-stage battery charger extends battery life
- Output options Normally ON and Switched or Normally OFF
- Summary Alarm Form C dry contacts
- Field selected input and output voltage 120V or 277VAC
- Indicator lights for charge, ready, inverter and test switch
- Warranty:
 Electronics - 3 years full (parts only)
 Battery - 1 year full / 9 years prorated



FEMA



ORDERING GUIDE

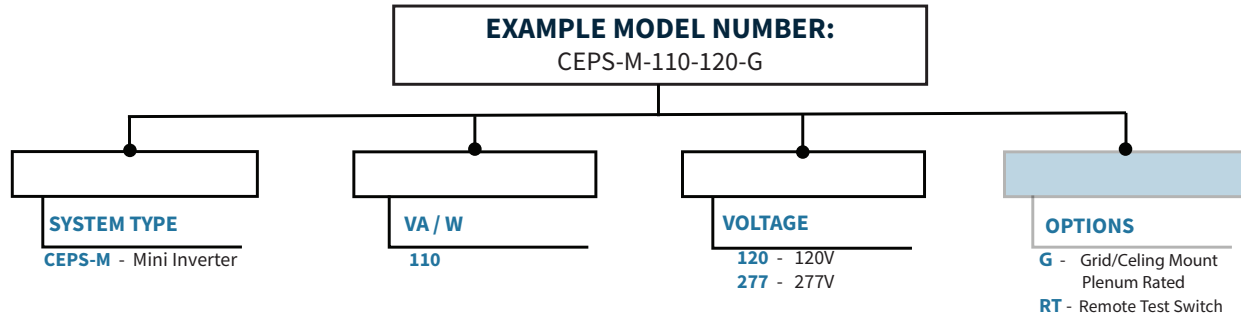

DIMENSIONS

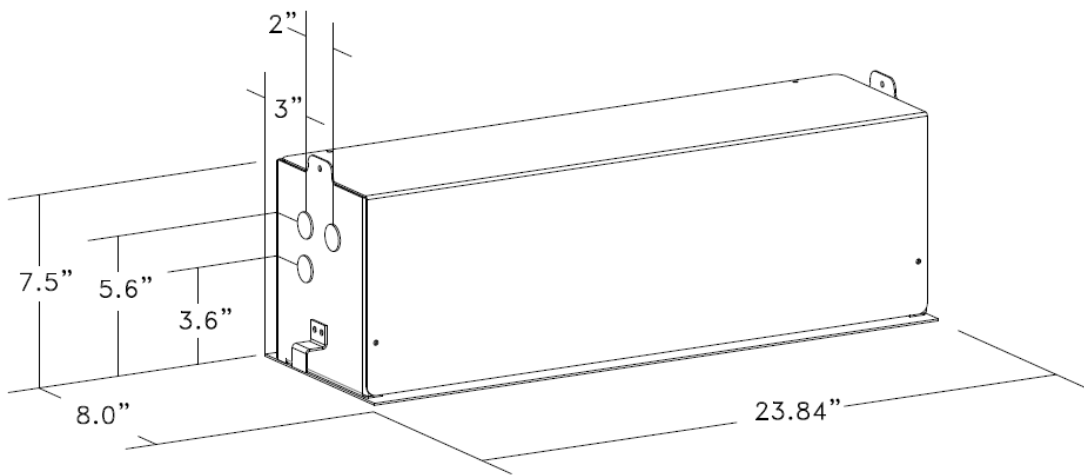

Grid Mount Style

Clearances

Top: 6"
Sides: 2"
Front: 12"

Weight

37 lbs

Conduit Knockout Size

1 1/8"

CEPS-110 Grid Mount	
Run Time (Minutes)	Output Power (Watts)
90 Minutes	110W
120 Minutes	80W
180 Minutes	55W
240 Minutes	45W
300 Minutes	30W
360 Minutes	25W