

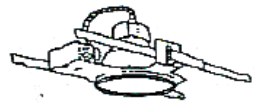

SAVINGS
IN
ENERGY & LAMP
REPLACEMENT
COSTS

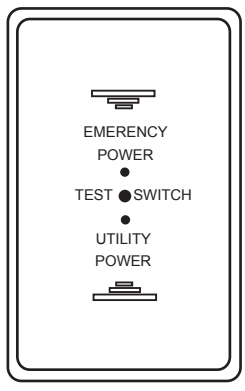
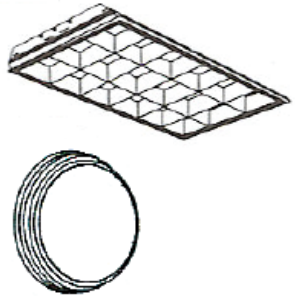

CONTROL
FLEXIBILITY
DURING
AUDIO & VISUAL
PRESENTATIONS

December 2009

Applications and Instructions of Model EPC & EPC-PM

In the past all emergency lights had to be on 24 hours a day to meet safety codes. However, now you can specify and install a UL 924 listed emergency power control device that can convert and control up to 20 regular light fixtures to approved emergency lights, which can then be turned on and off in the same manner as your regular lights. The emergency power control Model EPC is ceiling mounted in a single gang plaster ring and is usually located in the room or area where the emergency fixtures are, or you can use a Model EPC-PM which is fast and simple to install in the appropriate junction box in the space above a suspended ceiling.

Method of Control

The emergency light fixtures' power is supplied by a 24 hour emergency power distribution panel. The utility power company normally supplies the power to this panel, but during a utility power failure this panel is automatically switched over to a local generator source by means of a UL 1008 transfer switch. The standard room switch turns both regular and emergency lights on and off through the same switch leg, by means of the Emergency Power Control, which controls the emergency light fixtures. You can save energy by using an EPC and turning your emergency lights on and off: manually with your room switch, or automatically with an occupancy sensor or energy management system. During a local or general power failure, these emergency fixtures will illuminate automatically, regardless of room switch on or off position, conforming to all life safety codes.

EPC Specifications and Features

- Fail safe operation
- Visible emergency power LED
- Visible regular power LED
- All components are surge protected
- Convenient to operate test switch
- Fast to install
-

The EPC is equipped with a green LED which indicates if regular utility power is available and field wiring is connected correctly. The red LED on the EPC has the same function for emergency power in a new installation. The above indicators will confirm the correct wire connections and continuity to branch panels and emergency panels.

Automatic Diagnostic Test Feature

Model EPC is equipped with an automatic diagnostic test feature which is initiated when the room switch is momentarily turned on and off. This simple, effortless test procedure will turn the emergency luminaires on for 5 seconds, indicating that an emergency power source is available and that the Model EPC, ballast, and lamp, are all functioning correctly. At all other times the room switch operates normally by turning both regular and emergency luminaires on at the same time. The unique advantage of the Model EPC is that it leaves only the emergency luminaires on for an additional 5 seconds after regular luminaires are turned off, providing safety and convenience while leaving the area. In addition it eliminates the use of a ladder during required testing every 30 days, which is usually done by a custodian.

Installation

- A qualified electrician should review and understand the installation instructions before installing or servicing the EPC in accordance with national/local codes and requirements. Check voltage and current requirements. Verify and lock out circuit breakers on both normal power and 24 hour night light circuit/emergency generator circuit.
- Install a self-adhesive 2" x 3" caution label outside of ballast channel in each fixture or load controlled by an EPC unit cautioning that this load is supplied from 2 different power sources, regular and emergency.
- Review wiring diagram and connect wires, one group at a time, in accordance with the numeric identification. In order to provide a safe light level when regular light is interrupted, it is recommended that a minimum of two 4' fluorescent tubes providing approximately 5000 lumen are controlled by a 24 hour emergency generator circuit and are spaced no farther than 24' in any direction from each other, in a normal 9' white ceiling environment.

Initial Testing and Trouble Shooting of EPC or EPC-PM

In a new installation, where 10 or 100 separate devices may be used, each having as many as 14 wires to be correctly connected, it is important that a fast convenient method is used to check the connections. In order to test that the wires are connected correctly, without any inconvenience to other occupants, do not turn off regular utility supplied power or turn on the emergency generator until you have checked each EPC device and light fixtures using the following methods.

1. Turn on all room switches and verify that all regular and emergency light fixtures are illuminated. Check if all red and green LED's are lit. Usually this can be done by walking around and looking up. Turn 1 or more lighting branch circuit breakers off at a time, and observe if regular light fixtures are off but emergency light fixtures are illuminated. At the same time, check that the green LED is off but the red LED is on at each device for correct polarity.
2. In the event that you cannot turn off branch circuit breakers, turn off room light switch and use the test switch on each device. All emergency lights should then illuminate in that room or area connected to this EPC. You can also use the Automatic Diagnostic feature in place of the test switch, by turning the room light switch to the on position, and then the off position, and observing that the emergency fixtures illuminate for 5 seconds.
3. Having completed the above test, you have established correct wire connections and continuity to branch panels and emergency panels. If any emergency light fixture has failed to illuminate, check power, fixture, and EPC device and replace defective item. You can now arrange a convenient time to turn off the main facility breaker. Turning off the main breaker in your facility will automatically start the emergency generator. The transfer switch will automatically switch all emergency panels to emergency generator power, and all emergency light fixtures will then be illuminated.

30 Day Normal Testing

When EPC controls are connected or used with an approved emergency system, the emergency system and startup controls are tested automatically every 30 days. Since the emergency light fixtures' ballasts are supplied from this source, rather than batteries, the 30 day normal testing is not required. However, some local inspectors may still require this. In that case, testing can be accomplished using the methods as described above.

Normal Operation & Trouble Shooting

1. When the normal room or area switch is on, emergency load and regular load fixtures should all be illuminated.
2. When regular utility electrical power is correctly connected and present on the EPC devices, it is indicated by the green status light. When the emergency power standby circuit is correctly connected and present on the EPC controls, it is indicated by the red status light. If the emergency load fails to come on after turning off the regular branch circuit breaker, check wiring connections, ballast, and fluorescent tubes. If all of the above conditions are correct, turn off the branch circuit breaker and emergency power circuit, disconnect the device completely and replace with a new unit.

Model EPC / EPC - PM 120V	Model EPC / EPC - PM 277V
120 VAC Ballast 20 Amp	277 VAC Ballast 20 Amp
120 VAC Tungsten 1800 Watt	277 VAC Tungsten 1500 Watt
General Use 20 Amp, 1 HP	General Use 20 Amp, 1 HP

Model EPC : Flush Mounted Size : 2-3/4" x 4-3/4" x 1/4"
Color: White ● Weight: 8 oz.
Ambient Temp Rating : 32°F - 140°F

Model EPC-PM : Plenum Mounted Size : 1-1/2" x 3-1/2" x 3"
Color: Black and Silver ● Weight: 8 oz.
Ambient Temp Rating : 32°F - 140°F

Maintenance

No routine maintenance is required to keep the EPC device functional. However, 30 day normal testing should be used when either the lamps or ballasts have been replaced or when facility remodeling has taken place.



Note: When using Model EPC do not control more than 10 ballasts per unit.
If more than 10 ballasts per unit are needed, use the EPC-PM.

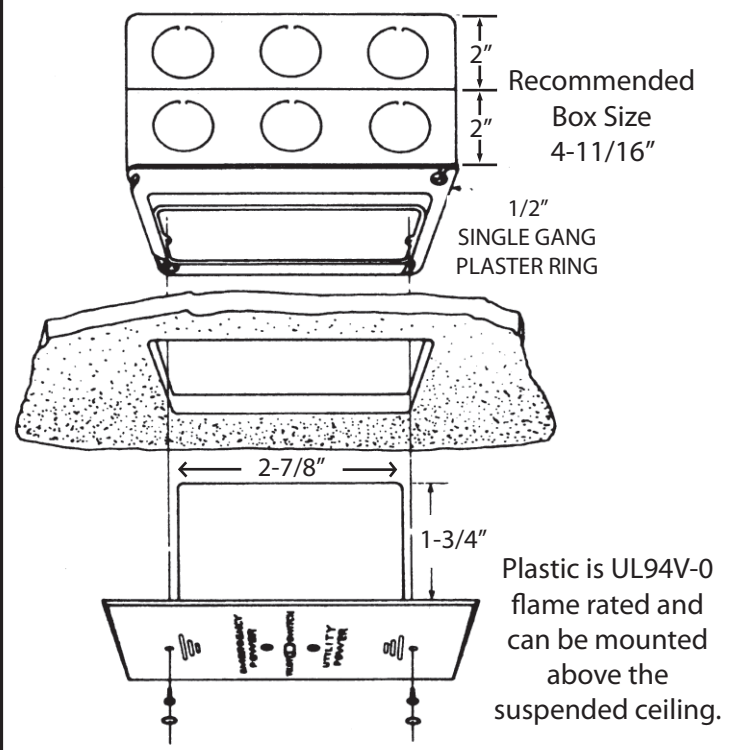
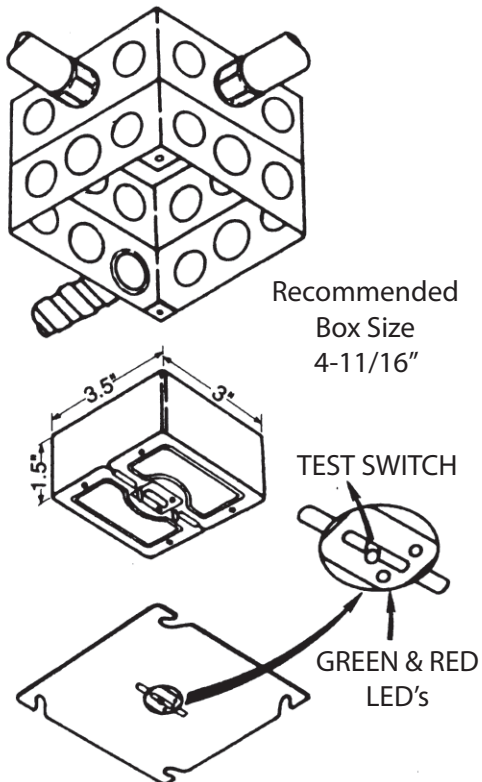

MODEL EPC WIRING DIAGRAM

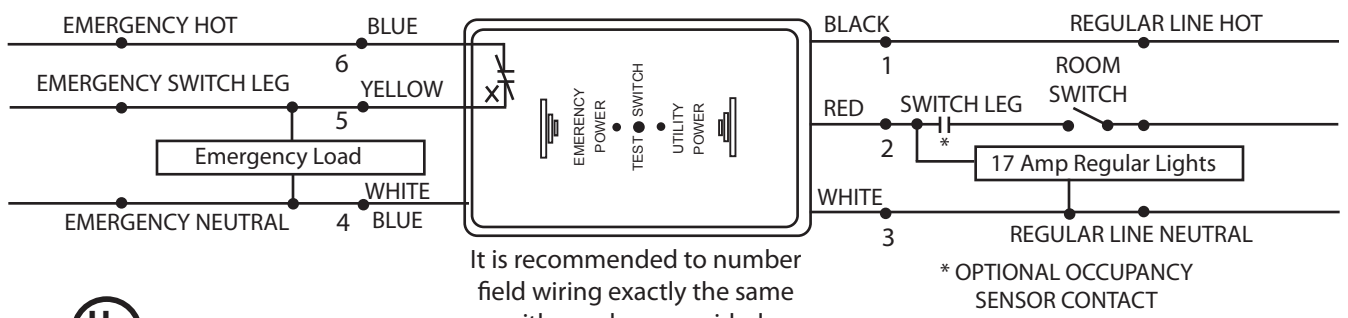

MODEL EPC-PM WIRING DIAGRAM

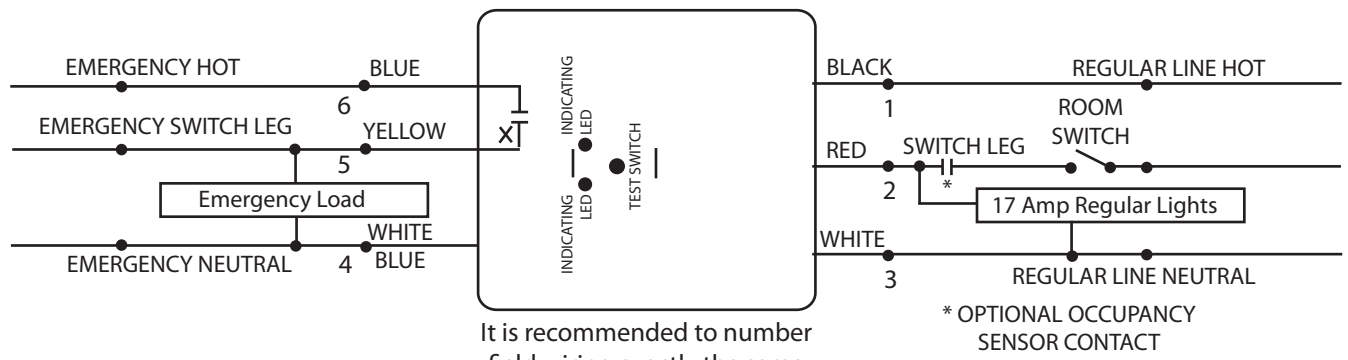

STANDARD LINE VOLTAGE SWITCHING LINE DRAWING

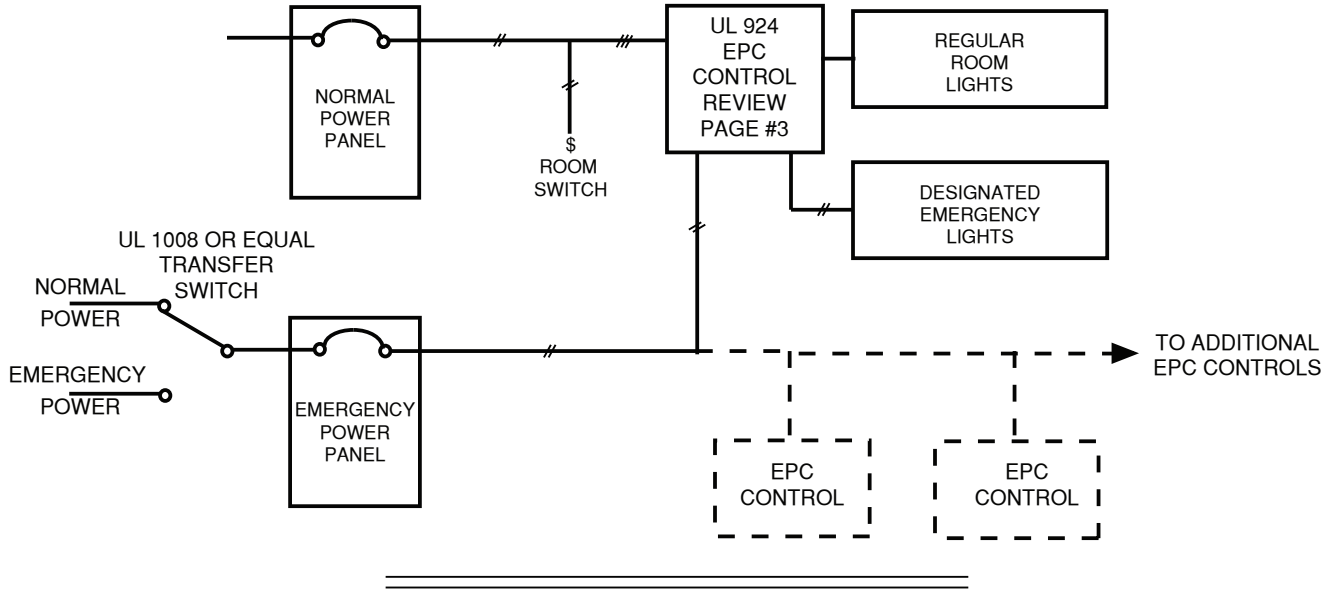

RELAY PANEL LOW VOLTAGE SWITCHING LINE DRAWING

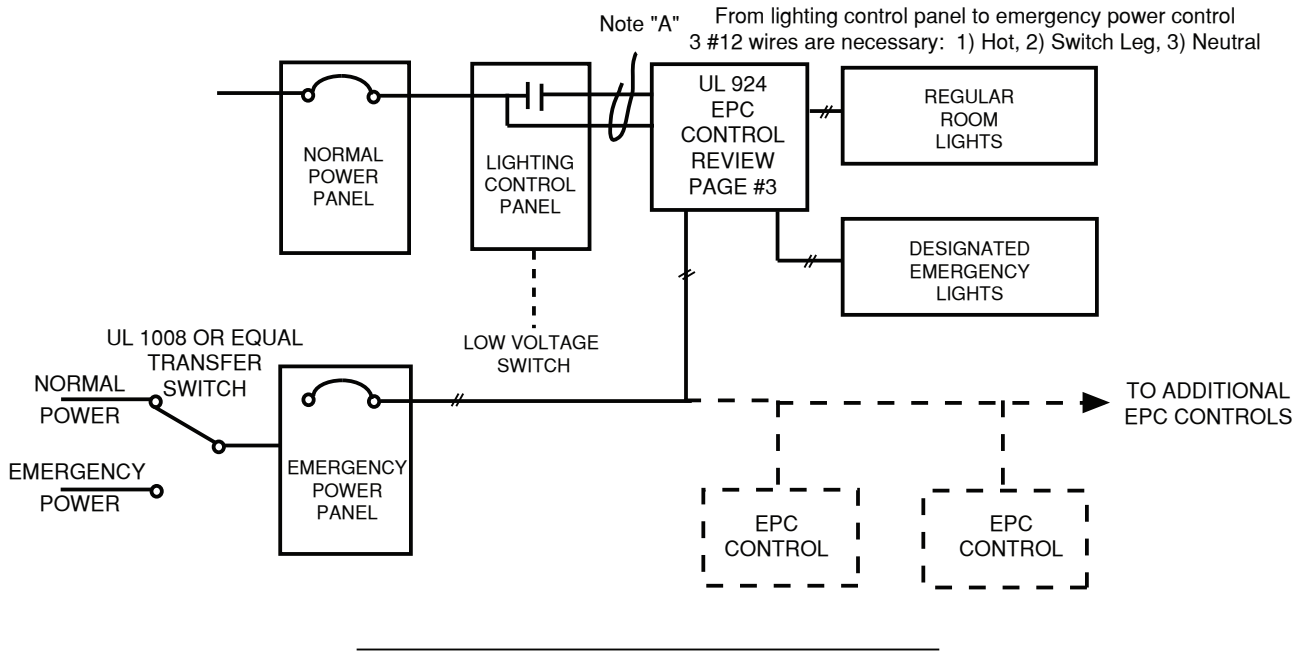

On a 20 Amp circuit, 1 emergency power control (Model EPC) can control up to 16 Amp of emergency lighting load, or 16 emergency power controls can each control 1 amp of emergency lighting load.

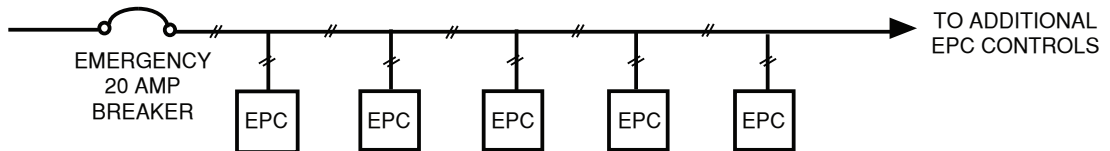

NOTE: Regular room lighting load does not affect EPC current rating. Room switch is only to control EPC 50 milli amp relay current coils, and regular lighting load. Regular line HOT connected to breaker and EPC is only drawing milli amps to sense if normal power is available. See EPC wiring diagram for clarification.



LVS, Inc. 2555 Nicholson St., San Leandro, CA 94577
Tel: 1-800-982-4587 Fax: 1-510-352-6707
www.lvcontrols.com