

SILENT SINGLE ZONE AUTOMATIC EMERGENCY POWER TRANSFER CONTROL FOR 2 WIRE, 3 WIRE, & 4 WIRE DIMMABLE LOADS

>> Applications <<

Designated dimmable emergency luminaires in public places such as auditoriums, restaurants, conference rooms, theaters, and classrooms.

>> Electrical Specifications / Approvals <<

LVS Emergency Power Controls are tested, approved, and listed by Underwriters Laboratories under UL 924 standards for designated emergency light fixture controls. They meet and exceed all pertinent code requirements from NEC, NFPA, OSHA, and life safety codes, in addition to major local codes.

>> EPC-D-F Features <<

Integral Test Switch

Integral Test Switch provides convenient anytime testing.

Voltage Surge Protection

Voltage Surge Protection insures reliable performance under adverse conditions.

Status Indicators

Separate indicating LED's for regular and emergency power allow verification of correct wiring connections.

Emergency Power Supervision Exclusive LVS Feature

An EPC-D-F uses internal supervision circuits to prevent emergency luminaires from illuminating during normal times if Emergency Hot or Neutral conductors have been interrupted.

This gives warning that a problem exists with emergency supply, which would otherwise be unnoticed, especially when controls are mounted above ceiling tile.

Triple Safety & Reliability

EPC-D-F consists of 2 contactors, C-1, and C-2.

C-1 is energized during normal times, and is deenergized when regular power is interrupted.

C-2 is energized when regular power is interrupted, and is deenergized when regular power is restored.

Internal C-1 Contactor

Voltage sensing interlock with C-2

Electrical contact interlock with C-2

1.5 second time delay interlock with C-2

Internal C-2 Contactor

Voltage sensing interlock with C-1

Electrical contact interlock with C-1

1.5 second time delay interlock with C-1

MODEL EPC-D-F

Universal Mounting: Can be mounted surface, above suspended ceiling, or flush.

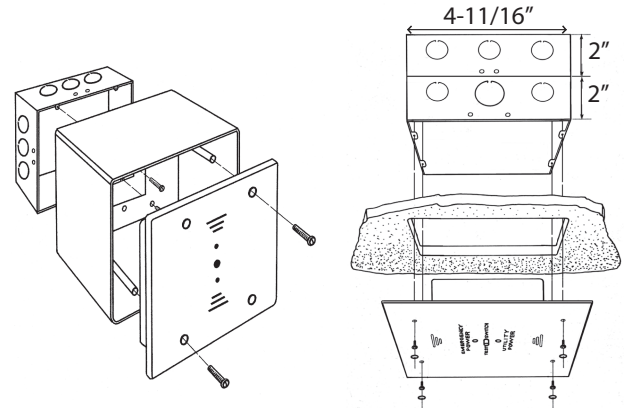

4-11/16" Back-up Box,
no plaster ring required



General Specifications

Flush Mounted Size : 6" x 6" x 1/4"

Color: White Weight: 16 oz.

Ambient Temp. Rating: 32° F - 140° F

UL 94V-0 Flame Rating on all EPC products. Safe for installation above suspended ceiling.

Electrical Specifications

Model EPC-D-F 120V

120 VAC Ballast 20 Amp

120 VAC Tungsten 1800 Watt

General Use 20 Amp

Model EPC-D-F 277V

277 VAC Ballast 20 Amp

General Use 20 Amp

All model EPC-D-F units are tested during production and upon completion are burned in.

5 YEAR LIMITED WARRANTY



LVS, Inc. 2555 Nicholson St., San Leandro, CA 94577

Tel: 1-800-982-4587 Fax: 1-510-352-6707

www.lvcontrols.com

SILENT SINGLE ZONE AUTOMATIC EMERGENCY POWER TRANSFER CONTROL FOR 2 WIRE DIMMABLE LOADS

Method of Operation

Model EPC-D-F single zone silent operating control is a versatile, cost effective unit, specifically designed for dimmable lights in public places where critical light levels of at least 1 foot candle must be maintained during a loss of normal utility power. The EPC-D-F senses a loss or voltage drop and within 1.5 seconds transfers the load to an available emergency source. When the normal utility power is restored, the EPC-D-F senses this and will transfer the load back to the normal utility power within 1.5 seconds. Momentary incorporated test switch simulates normal power failure and can be performed anytime. Any interruption of normal utility power will automatically transfer designated emergency lights to the full bright condition regardless of whether the dimming system is in operation or turned off.

Installation

EPC-D-F is designed to be installed as a wiring device in the area the dimmable lights are, or in a central location. A qualified electrician should review and understand installation instructions before installing or servicing the EPC-D-F in accordance with national/local codes and requirements.

CAUTION: This unit shall be wired with a conductor that has an insulation rating of at least 75°C.

The unit shall not be installed in j-boxes with through branch wiring.

Check voltage and current requirements. Verify and lock out circuit breakers on both normal power and 24 hour night light/emergency generator circuit. Install a self-adhesive 2" x 3" caution label outside of ballast channel in each fixture/load controlled by an EPC-D-F unit, cautioning that load is supplied from 2 different power sources, regular and emergency.

CAUTION

This light fixture is powered by 2 circuits. The 24 hour night light circuit / emergency circuit must be turned off in addition to the regular power branch circuit breaker before servicing this light fixture.

Review wiring diagram and connect wires, one wire at a time, in accordance with the numerical identification. In order to provide a safe light level, when regular power is interrupted, it is recommended that a minimum of two 4' fluorescent tubes providing approximately 5000 lumen are controlled by a 24 hour emergency circuit and are spaced no farther than 24' in any direction from each other in a normal 9' white ceiling environment.

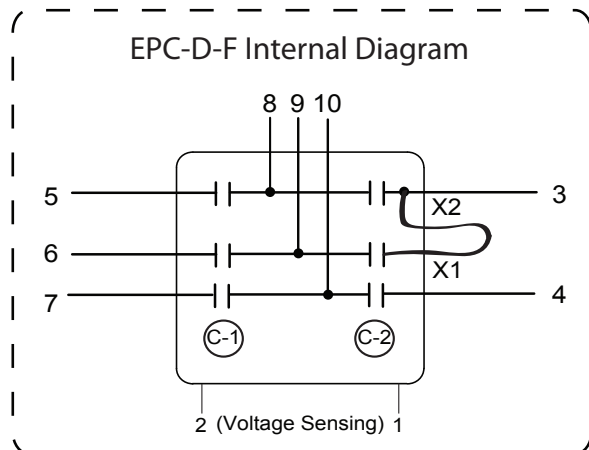
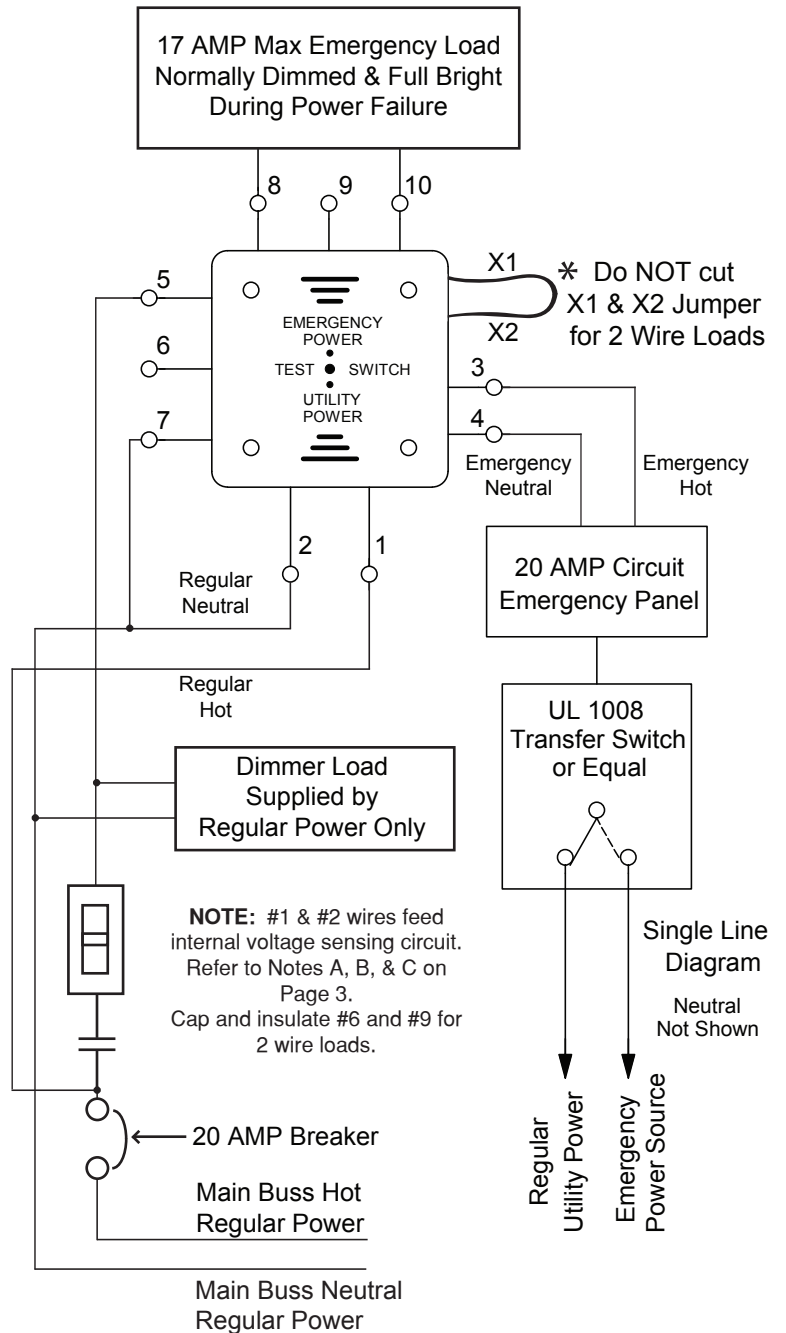

SILENT SINGLE ZONE AUTOMATIC EMERGENCY POWER TRANSFER CONTROL FOR 3 WIRE DIMMABLE LOADS

Initial testing after installing EPC-D-F

1. Turn on regular power circuit breaker and if all wire connections are correct, utility power green LED will be illuminated.
2. Turn on 24/7 emergency circuit breaker. At this time emergency circuit power is still derived from utility power, and if all wire connections are correct, emergency power red LED will be illuminated.
3. Do not turn dimmer system on but only press test switch on EPC-D-F. Designated emergency light fixtures should then come on full bright. These fixtures would also come on full bright if regular utility power circuit breaker is turned off. This is another testing method to use.
4. When regular utility breaker is on, operate dimmer control and observe if all fixtures light up, including designated emergency fixtures and if dimmer system lights respond normally when adjusted from low to high level.

Final Testing

- A. Coordinate with occupants a convenient time that the main circuit breaker can be turned off, and test all emergency lights.
- B. When main circuit breaker is turned off UL 1008 transfer switch or equivalent will automatically change position and emergency circuits will now be powered from either a generator, inverter, or UPS emergency source system.
- C. All designated emergency light fixtures will now be full bright regardless of whether the dimming system was turned on or off, and this is the intended function of the LVS Model EPC-D-F and conforms to UL 924 standards.

Review wiring diagram and connect wires, one wire at a time, in accordance with the numerical identification. In order to provide a safe light level, when regular power is interrupted, it is recommended that a minimum of two 4' fluorescent tubes providing approximately 5000 lumen are controlled by a 24 hour emergency circuit and are spaced no farther than 24' in any direction from each other in a normal 9' white ceiling environment.

- NOTE A:** #1 & #2 wires feed internal voltage sensing circuit inside EPC-D-F and are isolated.
- NOTE B:** 20 Amp emergency circuit can feed several EPC-D-F's to supply the connected emergency load provided the total emergency load does not exceed a safe load.
- NOTE C:** 20 Amp circuit from panel can also be from a 20 Amp breaker in dimmer cabinet.

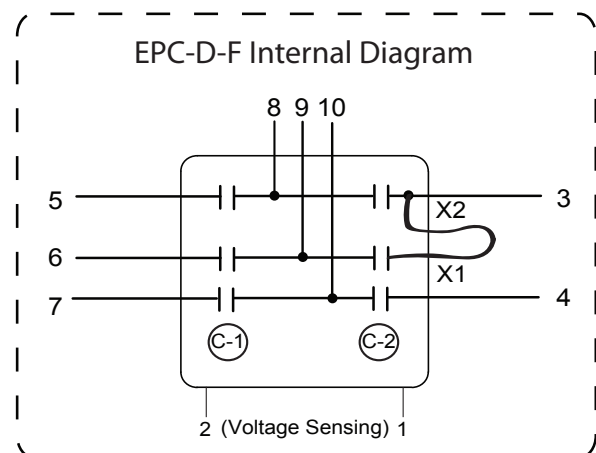
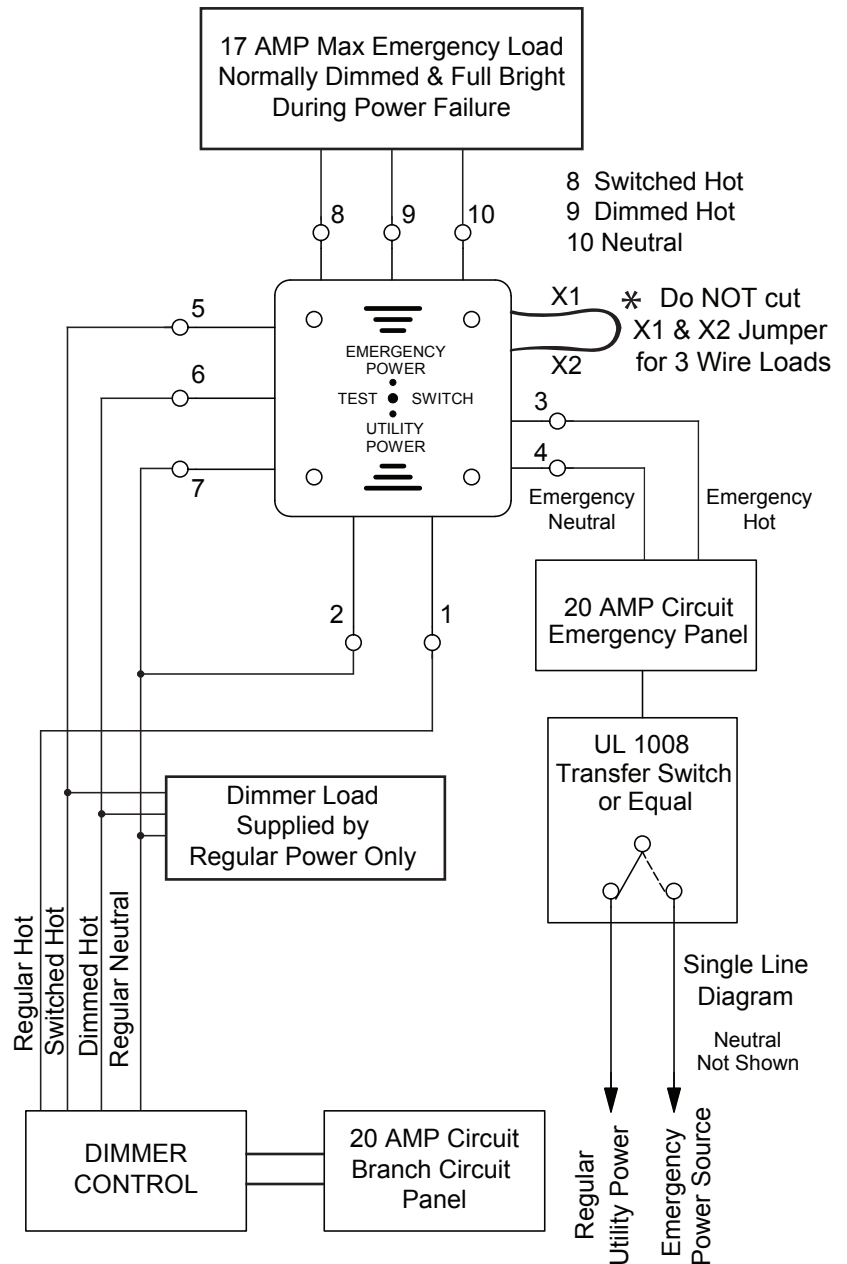

SILENT SINGLE ZONE AUTOMATIC EMERGENCY POWER TRANSFER CONTROL FOR 4 WIRE DIMMABLE LOADS (0-10V & DIGITAL BALLASTS)

EPC-D-F

Theory of Operation: 0-10V & Digital Loads

When utility power on #1 and #2 is interrupted, emergency dimmed ballast will then be automatically switched, after a time delay, to emergency power. After #1 and #2 power is interrupted, low voltage control signal (violet wire) is automatically interrupted and causes the designated emergency dimmed ballast loads to automatically go to full brightness. This sequence of events will occur whether the system is turned on or off. The emergency load connected to #8 and #10 cannot exceed rating of EPC-D-F. The load connected to #5 and #7 is not controlled by EPC-D-F and therefore EPC-D-F rating is not applicable.

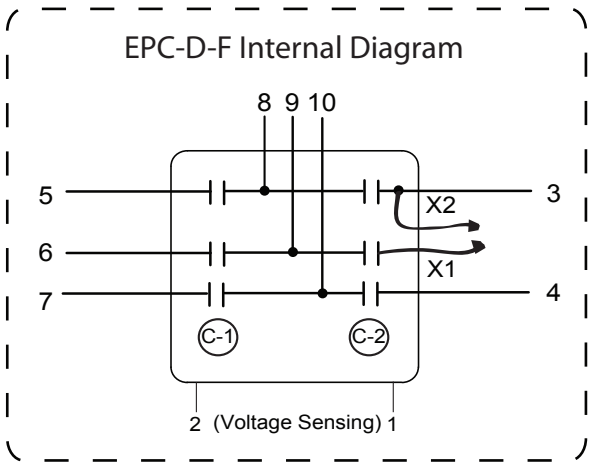
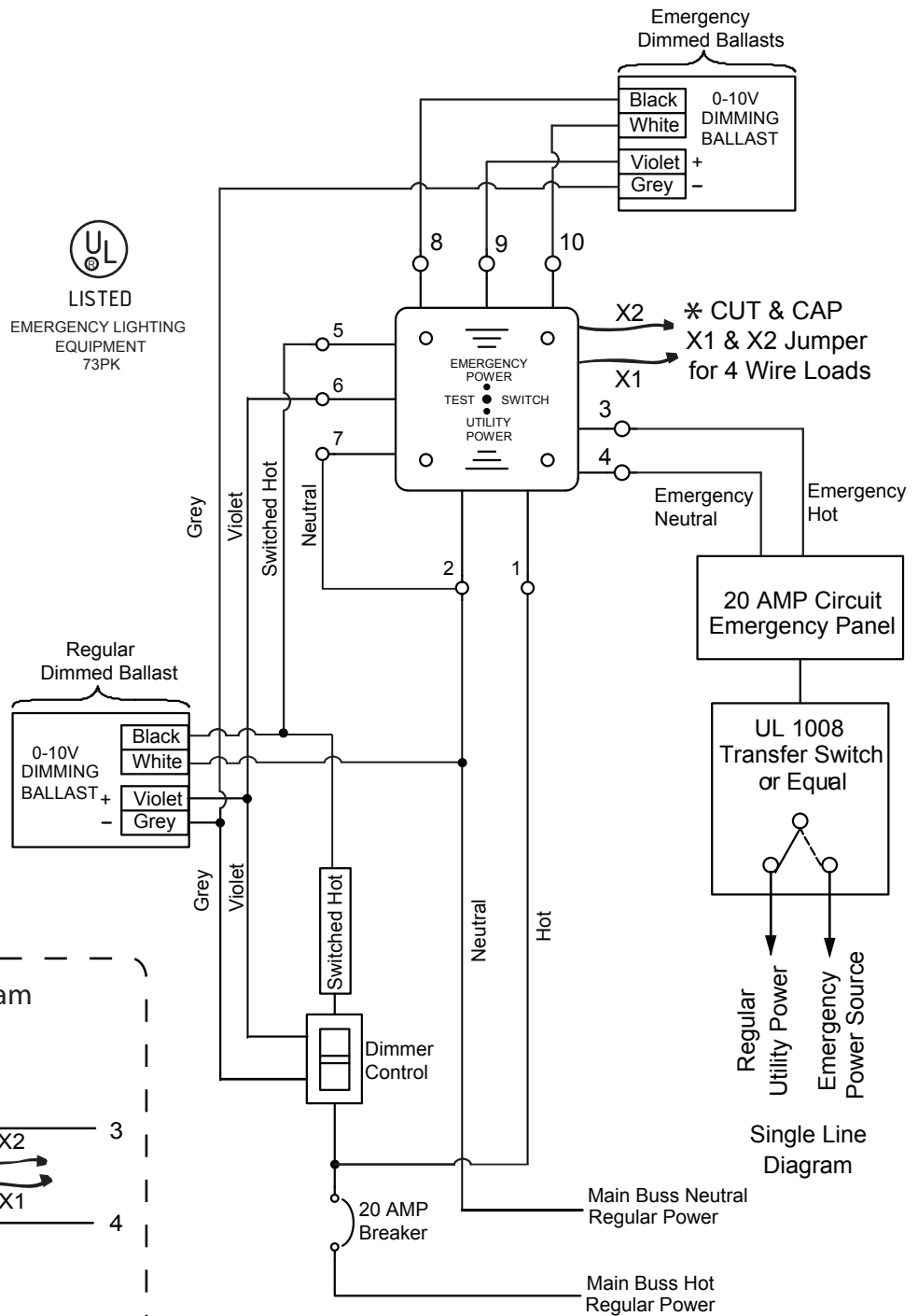

Single Line Diagram



LVS, Inc. 2555 Nicholson St., San Leandro, CA 94577
Tel: 1-800-982-4587 Fax: 1-510-352-6707
www.lvcontrols.com