

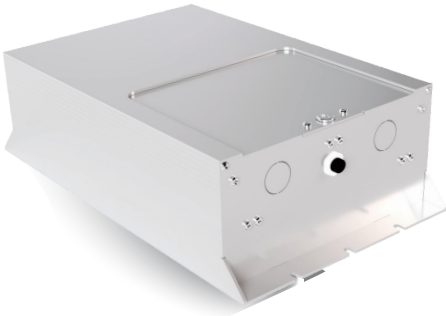

# CEPS-125W & 250W

Single Phase Systems

**CEPS-125W UNIT**  
(Standard Wall/Flush Mount)



**SCALED COMPARISON**  
(Grid Mount)

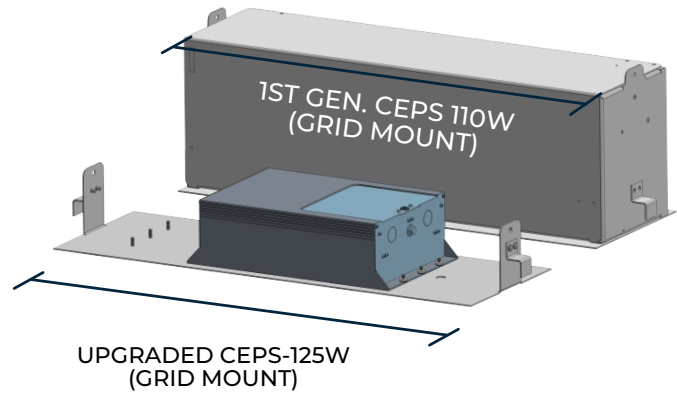

UL 924 | CSA C22.2 No.141-15

## Smarter, Stronger, Smaller comes Standard

### SMARTER



- **Automatic Voltage Detection** eliminates field wiring error
- **Automatic Bypass** overrides local switching and dimming controls
- **Automatic 0-10V Dimming** allows larger outputs to be supported safely
- **Automatic Monthly Testing** eliminate manual monthly testing demands

### STRONGER



- A **power increase of over 10%\***
- **LiFePO<sub>4</sub> Battery Chemistry** for safer, lighter & longer lasting batteries
- **Robust Temperature Range** (0-50° C); operates at 50/60 Hz
- **Plenum Rated**

### SMALLER

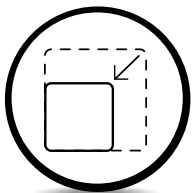

- More than **65% Decreased Volume\***
- Over **40% Decreased Weight\***
- Advanced High Frequency design is highly efficient and compact

*\*compared to previous generation of LVS' CEPS-110W*

# CEPS-125W

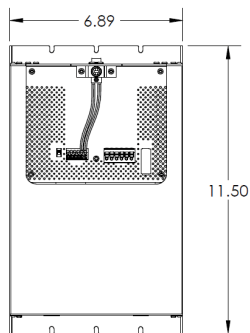

CEPS-125 only

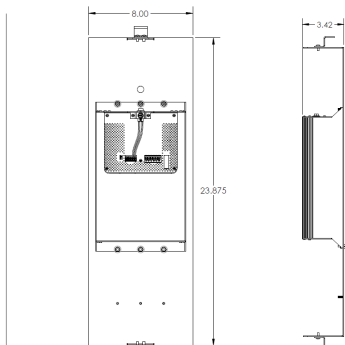

CEPS-125 with Grid Mount

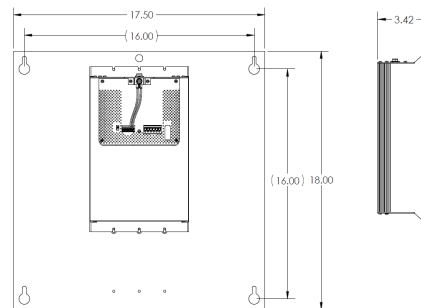

CEPS-125 with Wall Mount

	Model #	Height (in)	Width (in)	Depth (in)	Weight (lbs)
Inverter Only	CEPS - 125	11.50	6.86	3.35	9.24
w/ Grid Mount*	CEPS - 125	23.875	8.00	3.42	13.64
w/ Wall Mount*	CEPS- 125	18.00	17.50	3.42	15.99

# CEPS-250W

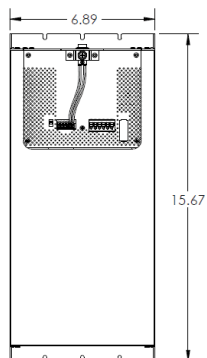

CEPS-250 only

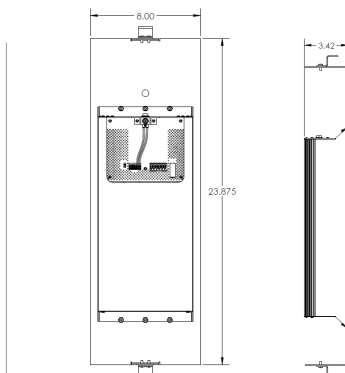

CEPS-250 with Grid Mount

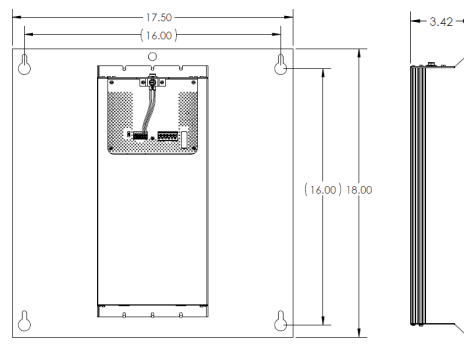

CEPS-250 with Wall Mount

	Model #	Height (in)	Width (in)	Depth (in)	Weight (lbs)
Inverter Only	CEPS- 250	15.67	6.86	3.35	15.40
w/ Grid Mount*	CEPS - 250	23.875	8.00	3.42	19.80
w/ Wall Mount*	CEPS- 250	18.00	17.50	3.42	22.15



# CEPS-125W & CEPS-250W

## SPECIFICATIONS

VOLTAGE		OUTPUT POWER		WARRANTY	
INPUT*	OUTPUT	CEPS-125	CEPS-250	ELECTRONICS	BATTERY
120V, 60Hz	120V, 60Hz	125W	250W	3 year standard	10 year prorated 2 year full
230V, 50Hz	230V, 50Hz				
277V, 60Hz	277V, 60Hz				

\*Automatic Voltage Detection increases Input capabilities

## ORDERING GUIDE

Example Model Number:

C E P S - 1 2 5 - W

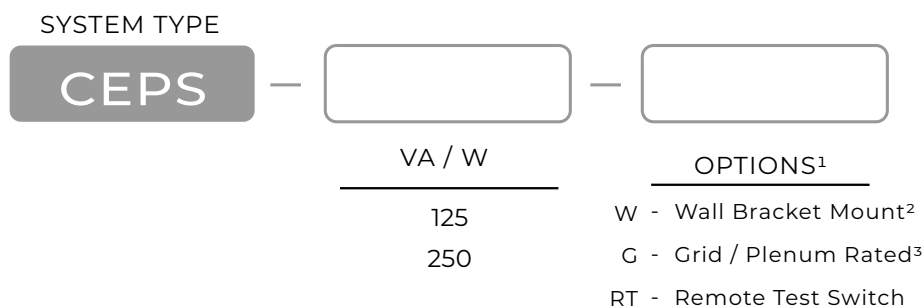

Please take note

1. See Mounting Guide for more in-depth descriptions of mounting options
2. Provides additional mounting bracket that allows unit to be mounted on 16" centers if required
3. Provides additional mounting bracket that allows unit to be mounted on in ceiling grid



# CEPS-125W & CEPS-250W

## 0-10V DIMMABLE SYSTEM

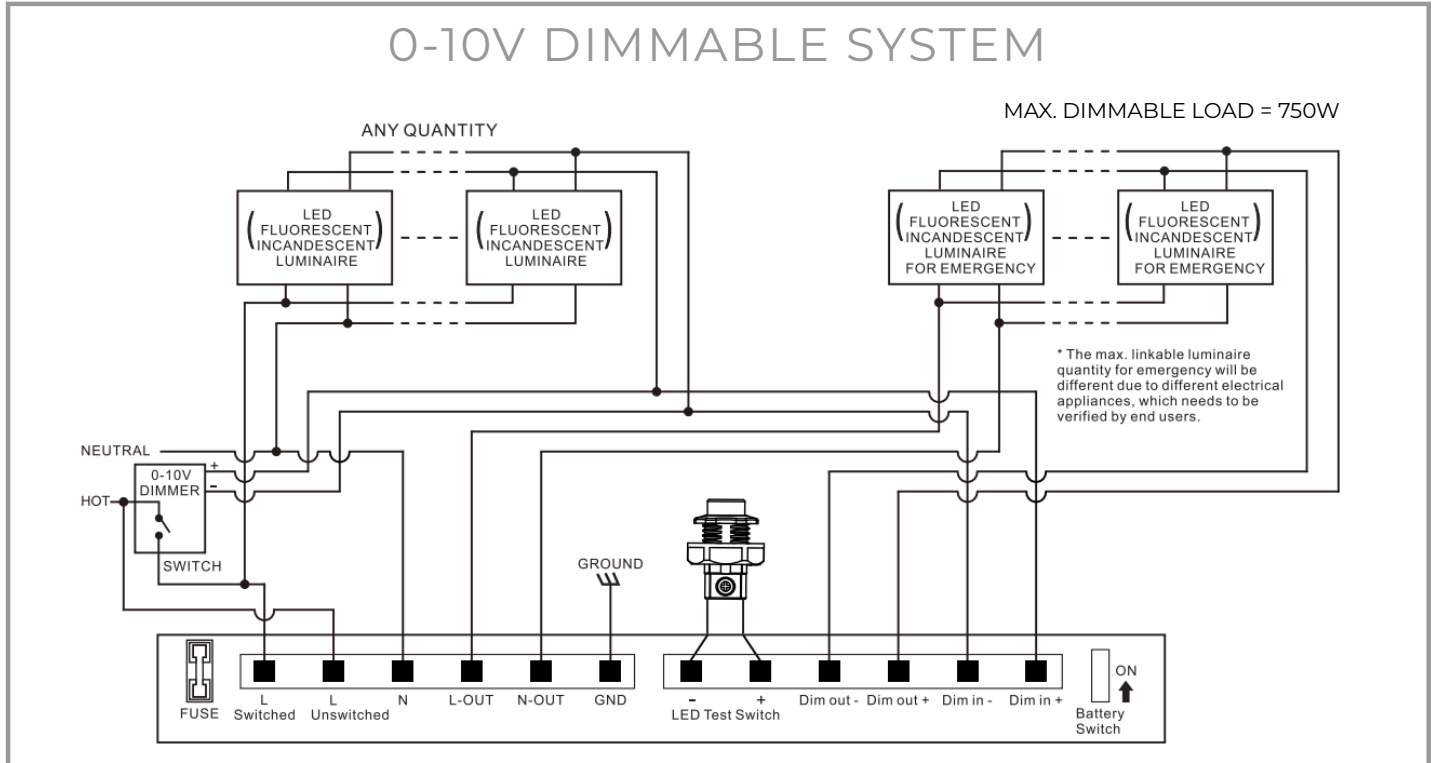

## NON - DIMMABLE SYSTEM

