

# EPC-2

## Emergency Power Control For Switched Loads

Project:

Model No.:

Comments:



## MOUNTING

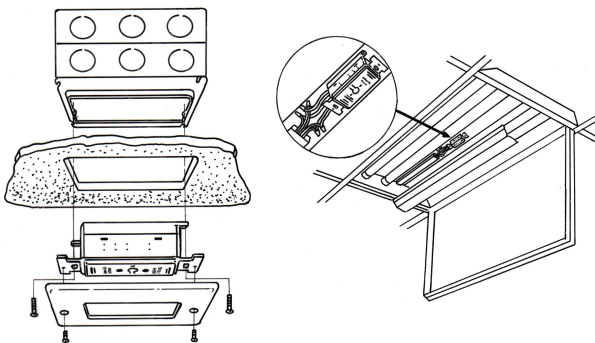

## APPLICATION

In the past, emergency lights were kept on 24 hours a day to meet life safety codes. Now, you can use a UL 924 listed [Emergency Power Control, Model EPC-2](#), to convert normal light fixtures into approved emergency lights. The [EPC-2](#) saves energy and money while ensuring compliance with both life safety and energy codes.

During normal operation, the same switch, occupancy sensor, relay panel, or lighting control can switch normal and emergency fixtures on and off simultaneously.

During a utility power interruption, the [EPC-2](#) automatically bypasses the normal lighting controls, turning the emergency lights ON, regardless of switch position.

The [EPC-2](#) is ceiling or wall mounted in a junction box with a single gang plaster ring and is usually located in the area where the emergency fixtures are installed.

## FEATURES

- Unique, Patented Automatic Diagnostic  
When the room switch is turned off, the [EPC-2](#) will run a 2.5 self-test routine, verifying that the emergency power source was available and that the [EPC-2](#), ballast, and lamp(s) are all functioning correctly. This feature eliminates the need for time-consuming and costly manual monthly testing and is approved for this purpose. This also allows the unit to be installed in remote or inaccessible locations, because the unit does not rely on access to its manual test switch.
- Fire Alarm, Remote Test
- Utility & Emergency Power Indicator LED's
- Slim, attractive flush mount profile allows easy access to manual test switch and LED's.



# SINGLE LINE DRAWING

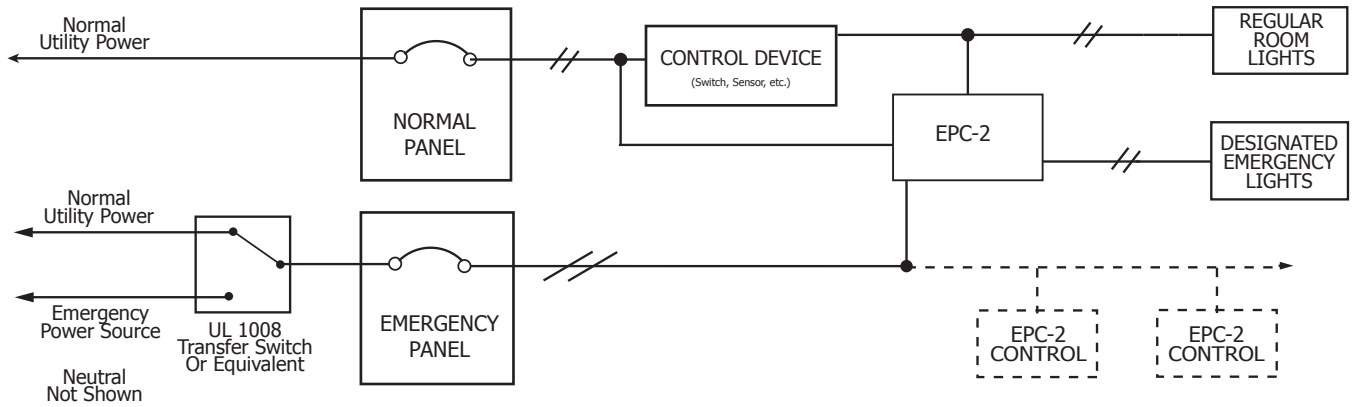

# WIRING DIAGRAM

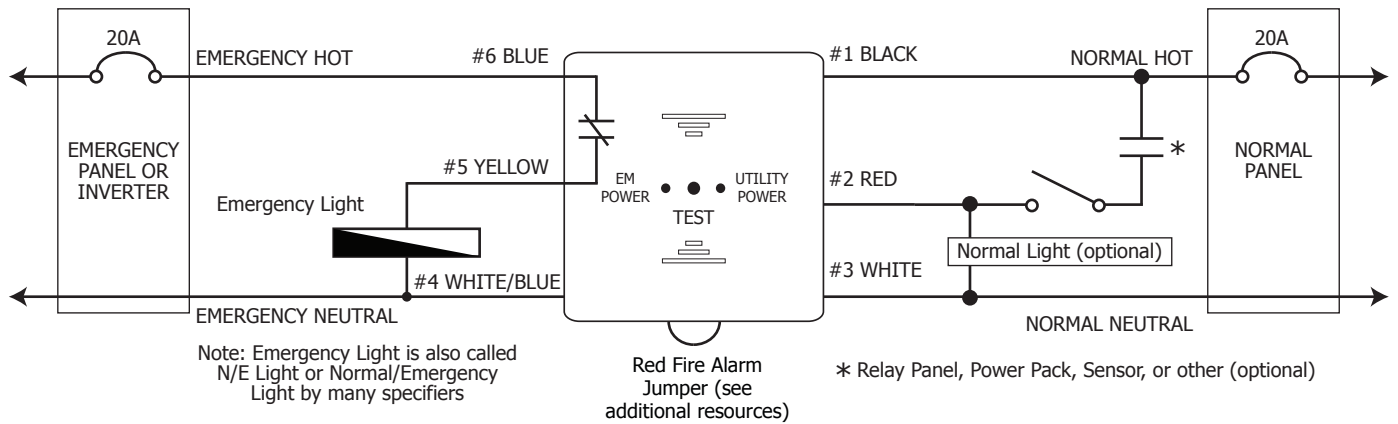

# SPECIFICATIONS

<b>ELECTRICAL</b>	MODEL NO.	EPC-2	<b>MECHANICAL</b>	MOUNTING	4-11/16" Junction Box w/ single gang plaster
	SENSING INPUT	120V - 277V		RATING	UL94-5VA
	LOAD RATING	120V - 277V (20A)		SHIPPING WEIGHT / COLOR	12 oz. / White
	BALLAST LOAD RATING	20A (120-277V)		TEMPERATURE	32°F - 140°F (0°C - 60°C)
	INCANDESCENT LOAD	1200W (120V) / 1500W (277V)		FLUSH MOUNTED SIZE	Single Gang Size
	WARRANTY	5 Year Replacement Warranty		BODY SIZE	1.7" x 3" x 1.2" (W x H x D body)

# ORDERING INFORMATION

EPC-2

# ADDITIONAL RESOURCES

- Installation Sheet
- FAQ Sheet
- Alternative Wiring Sheet
- Terms & Conditions/Warranty Information
- Fire Alarm Tie-In/Override  
<https://www.lvscontrols.com/blog/ul92fai>