

MODEL EPC-D-F-LS INSTALLATION INSTRUCTIONS

! IMPORTANT SAFEGUARDS !

WHEN USING ELECTRICAL EQUIPMENT, BASIC SAFETY PRECAUTIONS SHOULD ALWAYS BE FOLLOWED, INCLUDING THE FOLLOWING:

READ AND FOLLOW ALL SAFETY INSTRUCTIONS

1. This product can be used with LED, ballast, tungsten, and general use loads.
2. Make sure all connections are in accordance with the National Electrical Code and local regulations.
3. To reduce the risk of electric shock, disconnect both normal and emergency power supplies before servicing.
4. This product is intended to be used to control indoor and outdoor located loads.
5. An unswitched AC power source is required (120-277VAC).
6. Do not install near gas or electric heaters.
7. Do not attempt to service a sealed Emergency Lighting Transfer Switch. When malfunctioning, return to the manufacturer: LVS, Inc. 2555 Nicholson Street, San Leandro, CA 94577.
8. The use of accessory equipment is not recommended by the manufacturer and may cause unsafe condition.
9. Do not use this product for other than its intended use.
10. Servicing should be performed by qualified service personnel.
11. Equipment should be mounted in locations and at heights where it will not readily be subjected to tampering by unauthorized personnel.

SAVE THESE INSTRUCTIONS

5-Year Limited Warranty

LVS, Inc. warrants to the original purchaser/user for the published warranty period from the date of shipment that should LVS instruments or equipment prove defective by reason of improper workmanship or material, LVS will repair or replace the same equipment without charge. This warranty does not cover defects or malfunctions arising from improper installation, operation or repair, or neglect, accident, or abuse. LVS will honor its warranty provided the equipment has not been physically damaged or improperly installed or connected. To obtain warranty/repair, the defective product should be shipped freight prepaid within the warranty period to the address below. To the extent permitted by applicable law, all warranties extending beyond repair or replacement as described above are disclaimed, including the implied warranties of merchantability and fitness for a particular purpose. Where applicable law prohibits disclaimers or the implied warranties of merchantability and fitness; those warranties are limited to 12 months from date of shipment. LVS provides a 90 day money back guarantee if equipment does not perform in accordance with LVS published specifications. The liability of LVS and its agents under all warranties is limited to repair and replacement as described herein and under no circumstances shall there be liability for any other kind of loss, damage, or labor, either consequential or for injury to person or property or otherwise.

Electrical Specifications

120-277V Sensing Input
16 Amp Ballast Load Rating (120-277V)
16 Amp General Use Rating (120-277V)
1920W Incandescent Load Rating (120V)
4432W Incandescent Load Rating (277V)

UL1008 Listed (usUL/cUL)
Patents pending



Mechanical Specifications

Mounts in 4-11/16" Junction Box with Extension Box
UL94-5VA Plastic Flame Rating
Shipping Weight: 22 oz Color : White
Temperature: 0°C-60°C (32°F - 140°F)
Flush Mounted Size: 6" x 6" x 1/2"
Body Size: 4-1/4" x 4-1/4" x 2-1/4"



LVS, LLC 15007 Wicks Blvd. San Leandro, CA 94577
Phone: 510-352-9600 1-800-982-4587
Web: WWW.LVSCONROLS.COM

Application

In the past, all emergency lights were left on 24 hours a day to meet safety codes. Now you can specify & install a **UL1008 Listed Emergency Lighting Transfer Switch EPC-D-F-LS**, which converts up to 16A of normal light fixtures to approved emergency lights. During normal operation, the EPC-D-F-LS feeds designated emergency lights from the normal power circuit and allows them to switch or dim with the same control as your normal lights. During a utility power interruption, the EPC-D-F-LS feeds designated emergency lights from the emergency power circuit, at full or reduced brightness, depending on dip switch setting.

Intended for use with 0-10V DIMMABLE LOADS (for line voltage dimming loads, see EPC-D-F-ATS).

Three testing methods:

Integral Test Switch provides convenient anytime testing.

Automatic Test Option provides automatic and monthly self-testing.

Fire Alarm/Dry Contact Option allows emergency lighting activation from fire, security alarm or remote test switch.

Four safety and reliability interlocks:

Voltage Sensing Interlock senses back-feed or erroneous voltage on load terminals during transfer through optically isolated sensors.

Time Delay Interlock ensures break-before-make transfer operation. Reduces or eliminates phase-phase arcing risk.

Relay Position Detection detects relay malfunction (such as welding) and alerts microprocessor to stop transfer to prevent phase-phase shorting across relays.

Mechanical Interlock unique contact arrangement of relays prevents normal and emergency sources from being connected, even if all other interlocks fail.

Surface Mount Installation

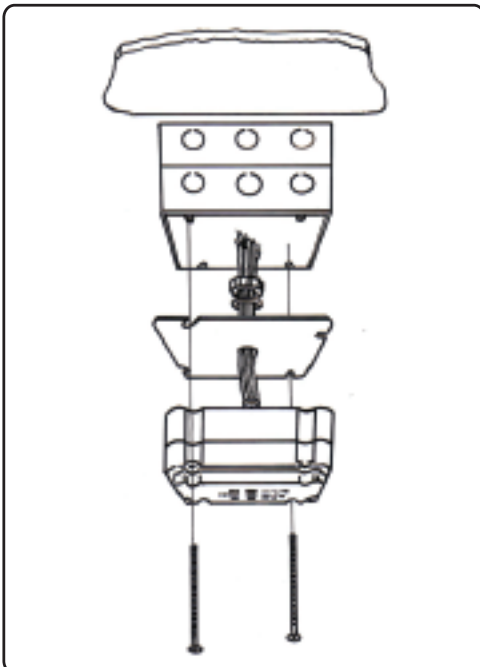

Flush Mount Installation

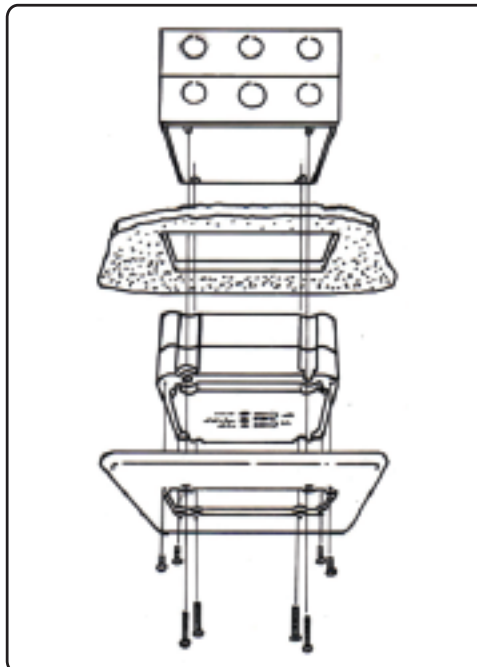

EPC-D-F-LS Includes:

Flush adaptor ring
Plastic 1/2" lock nut

Suggested Box:

(Not included)
4-11/16" (2-1/8" deep)
and 2-1/8" Extension Box

For plenum applications:

Suggested Box: 6x6 or
8x8 box with blank cover
(Not Included)

Plenum rated test switch
is available upon request

Method of Operation

The model EPC-D-F-LS is a single-zone silent transfer switch for emergency lighting applications. Versatile, small, and cost effective, and designed to work with 0-10V Dimmable loads.

EPC-D-F-LS is compatible with LED and Fluorescent load types. The EPC-D-F-LS allows normal and emergency lighting to be dimmed from the same dimmer during normal operation. During emergency operation (power interruption), the EPC-D-F-LS will transfer the emergency lighting to the emergency power source (generator or inverter) and bypass all local dimming controls. It will bring the emergency lighting to a pre-determined level set by the DIP switch on the EPC-D-F-LS. A momentary test switch on the front cover allows the user to simulate a power interruption when pressed.

Installation

In order to install device in accordance with national/local code requirements, a qualified electrician should review & understand the installation instructions. Check voltage & current requirements. Verify & lock out circuit breakers on both regular (utility) power & 24 hour emergency generator or inverter circuit. Install a self-adhesive 2" x 3" caution label in each fixture or load controlled by an EPC-D-F-LS unit cautioning that this load is supplied from 2 different power sources, regular & emergency. Review wiring diagram & connect wires, one at a time, in accordance with the numeric identification.

Initial Testing

1. Turn on normal power circuit breaker, utility power GREEN LED should be illuminated.
2. Turn on 24/7 emergency power circuit breaker, emergency power RED LED should be illuminated.
3. Do not turn dimmer system on yet. Press test switch EPC-D-F-LS . Designated emergency fixtures should come on at full brightness. Alternatively, you may turn off the normal power breaker to test the EPC-D-F-LS .
4. With normal power breaker on, operate the dimmer control and observe if all fixtures turn on, including designated emergency fixtures. Load BLUE LED should be illuminated when load is on.

Final Testing

1. Coordinate a convenient time to turn off the main circuit breaker with building occupants.
2. With main circuit breaker off, emergency circuits will be powered by the generator, inverter, or UPS.
3. Emergency luminaires connected to EPC-D-F-LS should be ON at full brightness, regardless of dimmer system setting. This is the intended function of LVS Model EPC-D-F-LS and conforms to UL1008, NEC, and NFPA101 requirements.

CAUTION
This light fixture is powered by 2 circuits: the 24-hour nightlight / emergency circuit must be turned off in addition to the regular power branch circuit breaker before servicing this light fixture.

Notes for use:

USE CU WIRE ONLY

Utiliser des fils en cuivre uniquement

Suitable for total system transfer.

Input: 120-277VAC 50-60Hz

Unit Power Consumption: 7W Max

Continuous Load Current not to exceed 100% of switch rating

120-277 volt 16 Amp Ballast

120-277 volt 16 Amp Tungsten

120-277 volt 16 Amp General Use







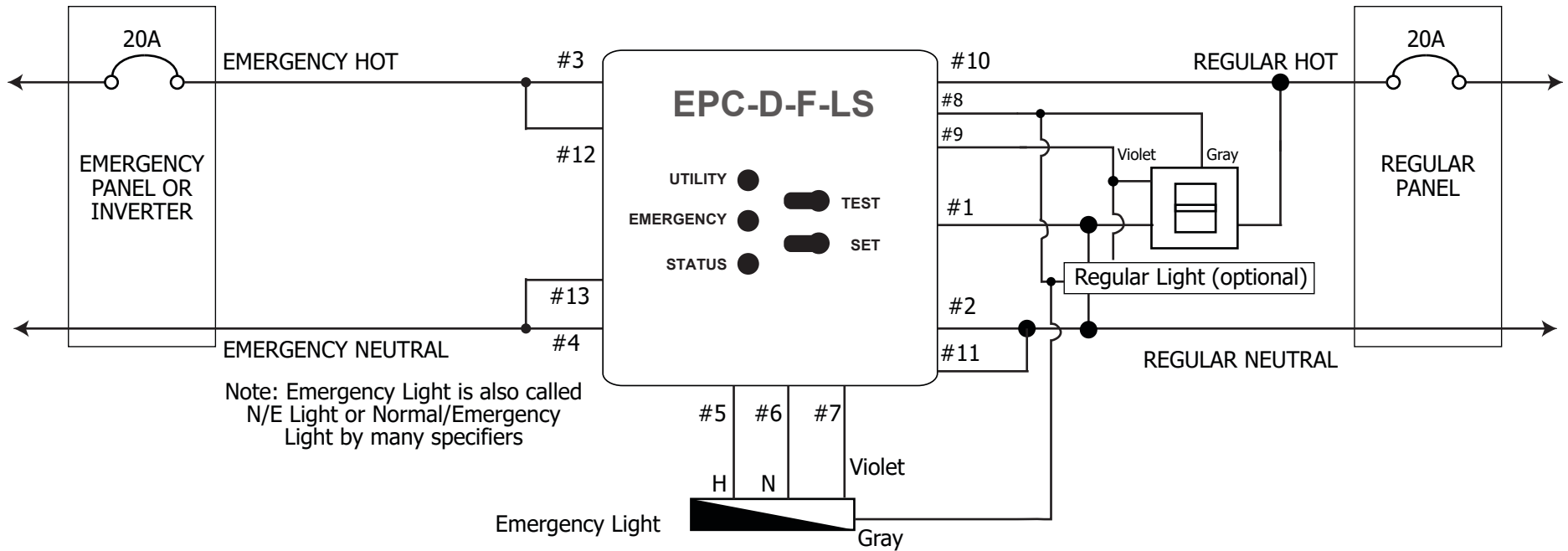









When protected by a fuse of the specific manufacturer, type, and ampere rating as marked below, this transfer switch is suitable for use in circuits capable of delivery 5000A at 277V.

Littelfuse	KLK-30	30 Amps
Littelfuse	KLKR-30	30 Amps

EPC-D-F-LS WIRING DIAGRAM



EPC-D-F-LS DIP SWITCH B SETTINGS

DIP 1,2	Em Light Output	DIP 3,4	Transfer Timing
ON  OFF  1 2 3 4	2.5V ~ 25%	ON  OFF  1 2 3 4	1 Sec
ON  OFF  1 2 3 4	5V ~ 50%	ON  OFF  1 2 3 4	1.5 Sec
ON  OFF  1 2 3 4	7.5V ~ 75%	ON  OFF  1 2 3 4	2.5 Sec
ON  OFF  1 2 3 4	10V ~ 100% (no dimming)	ON  OFF  1 2 3 4	4 Sec

Note: During normal operation, emergency and regular lights can be controlled by dimmer.

























During emergency operation, emergency lights will be set to "Em Light Output" Setting according to DIP switch.

%s are estimates based on DC voltage and vary by manufacturer.

Note: Transfer timing setting can be used to reduce overall inrush current, by staggering the starting of emergency lights spread across multiple EPC-D-F-LS units.

For best operation, set roughly the same number of units for reach timing setting.

EPC-D-F-LS DIP SWITCH A SETTINGS

<p>ON  No Monthly Automatic Test No Fire Alarm/Remote Test Switch</p> <p>OFF  1 2 3 4</p> <p style="text-align: center;">DEFAULT</p>	<p>No Monthly Automatic Test YES Fire Alarm/Remote Test Switch (N/C)</p> <p>ON  1 2 3 4</p> <p>OFF </p>		
<p>ON  YES Monthly Automatic Test No Fire Alarm/Remote Test Switch</p> <p>OFF  1 2 3 4</p>	<p>YES Monthly Automatic Test YES Fire Alarm/Remote Test Switch (N/C)</p> <p>ON  1 2 3 4</p> <p>OFF </p>		
<p>ON  No Monthly Automatic Test YES Fire Alarm/Remote Test Switch (N/O)</p> <p>OFF  1 2 3 4</p>	<p>YES Monthly Automatic Test YES Fire Alarm/Remote Test Switch (N/O)</p> <p>ON  1 2 3 4</p> <p>OFF </p>		
<table style="width: 100%; border: none;"> <tbody> <tr> <td style="width: 50%; border: none; padding-right: 20px;"> <p>ON  No monthly automatic test No Fire alarm/remote test switch Extended transfer delay: (2.5 second normal to emergency) (2.5 second emergency to normal)</p> <p>OFF  1 2 3 4</p> </td> <td style="width: 50%; border: none;"> <p>ON  No monthly automatic test Yes Fire alarm/remote test switch Extended transfer delay: (2.5 second normal to emergency) (2.5 second emergency to normal)</p> <p>OFF  1 2 3 4</p> </td> </tr> </tbody> </table> <p style="font-size: small; margin-top: 10px;">Note: extended transfer delay mode is recommended for use with Lutron® LimeLight® or Vive® or Ketra® systems when utilizing their power loss detection software to activate emergency modes of operation.</p>		<p>ON  No monthly automatic test No Fire alarm/remote test switch Extended transfer delay: (2.5 second normal to emergency) (2.5 second emergency to normal)</p> <p>OFF  1 2 3 4</p>	<p>ON  No monthly automatic test Yes Fire alarm/remote test switch Extended transfer delay: (2.5 second normal to emergency) (2.5 second emergency to normal)</p> <p>OFF  1 2 3 4</p>
<p>ON  No monthly automatic test No Fire alarm/remote test switch Extended transfer delay: (2.5 second normal to emergency) (2.5 second emergency to normal)</p> <p>OFF  1 2 3 4</p>	<p>ON  No monthly automatic test Yes Fire alarm/remote test switch Extended transfer delay: (2.5 second normal to emergency) (2.5 second emergency to normal)</p> <p>OFF  1 2 3 4</p>		

Monthly Automatic Test feature will test EPC-D-F-LS for 40 seconds every 25 days and record result on microprocessor. Test results may be played back by holding test button for 3 seconds. Once green LED flashes once, release test button. Every green flash signals a passed test, every red flash signals a failed test. Annual testing for 90 minutes is still required and recommended.

Fire Alarm/Remote Test switch input is optional. Cut red jumper wire and connect 24V DC power to it through a dry contact. For N/C type, when contact is open EPC-D-F-LS will transfer to emergency source. For N/O type, when contact is closed EPC-D-F-LS will transfer to emergency source.

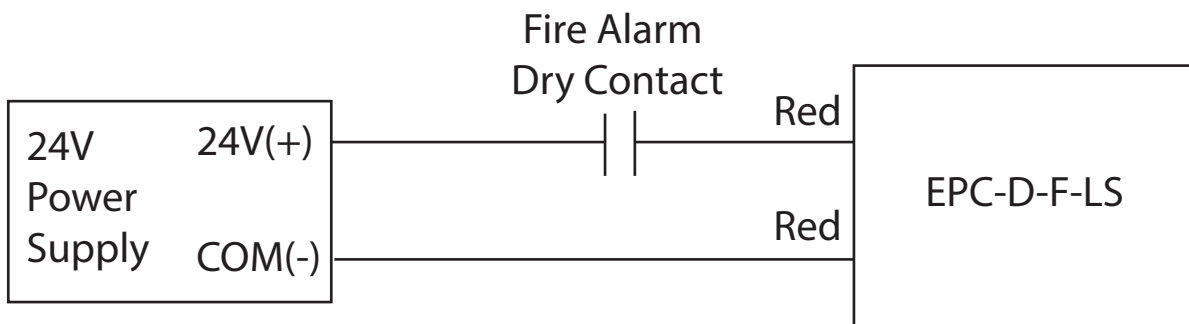

Note: EPC-D-F-LS red wires are polarity independent